

Instruction manual

for screw conveyor



Hiya Mechanical Equipment Co., Ltd.

Thank you for using our serial screw conveyors.

All our products have been inspected and tested according to our quality standard procedures. Before using the machine, please read the instruction manual in details to ensure the safety and reliability of the product

Precautions before using

1. Check if the model No., specification, size and spare parts are exactly what you've ordered.
2. Check if the machine has been damaged during transportation
3. Use appropriate grease oil
**** Use Mobil CEAR629# or Shell 150# for the gear reducer

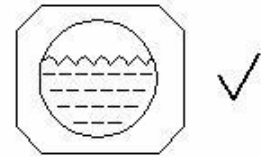

Precautions:

- I Do not use mixture of oil
- II Oil under 2/3 level of the Inspection window (see the figure at right) III Less oil will cause malfunctioning and damage to the machine
- IV More oil will increase the temperature and pressure in the gearbox
- V Refill oil when the Screw conveyor is not running
- VI Use clean and qualified oil, and refill oil in time.

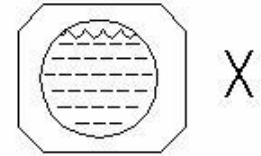

**** Use Mobil MP grease oil for the Intermediate support and End support.

Introduction to the product

Construction diagram of the Screw conveyor (Fig. A)

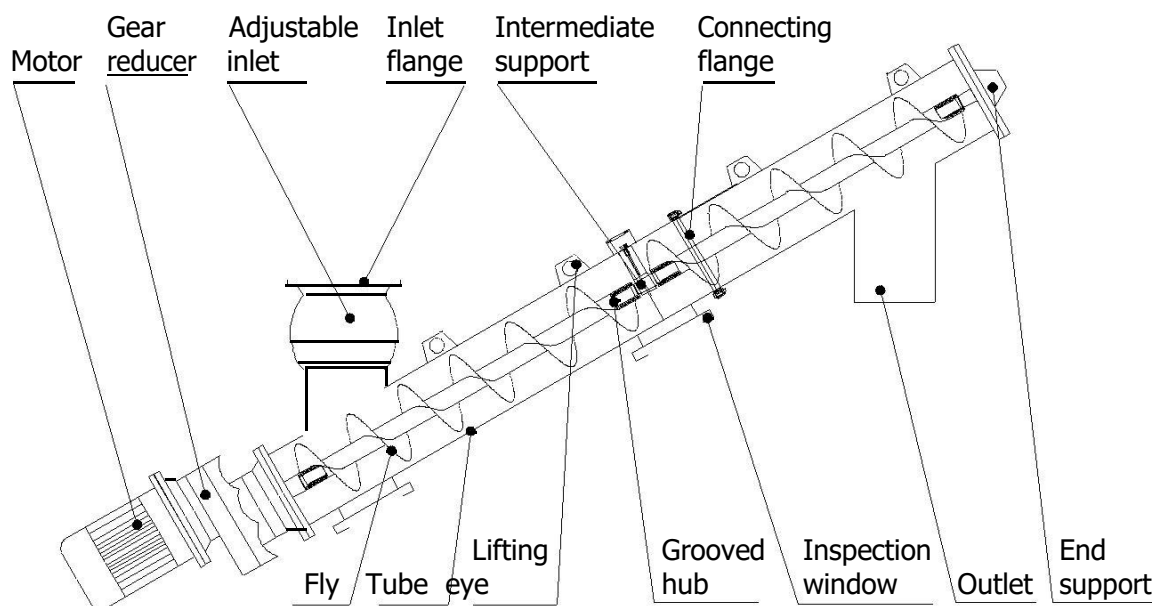

1. Screw conveyor is the key equipment in a mixing station. The working principle is as follows:

The Fly is driven by Motor and Gear reducer to transfer the cement powder & components continuously or discontinuously.

2. Main parts of a Screw conveyor: Motor, Gear reducer, Tube, Fly, Intermediate support, End support, Adjustable inlet, and Inlet Flange.

Main advantages of using Screw conveyors: low noise, good sealing, and convenient installation.

3. Technical data: Model No., Screw length, Screw angle, Capacity, Inlet connection

- ① Model No. is indicated as the diameter of the tube. Bigger diameter, larger conveying capacity.
- ② Screw length (L): Inlet to Outlet distance.
- ③ Screw angle (A): the angle between Screw conveyor and the horizontal. Bigger angle, smaller capacity conveyed.
- ④ Screw capacity (T/h): the utmost quantity conveyed in one hour. Unit: Ton / Hour.
- ⑤ Inlet connection: with Adjustable inlet for convenient adjustment during installation.

Assembly and Use

1. Mechanical assembly

- ① Remove the iron fastening of the Fly
- ② Mount the sealing pad
- ③ Add grease oil to all the supports
- ④ Turn the Fly clockwise slowly to fix the Grooved hub and Intermediate support
- ⑤ Push in the Tube and Fly
- ⑥ Adjust the Tubes to parallel the Connecting flange
- ⑦ Lock the screws
- ⑧ Adjustable inlet: Adjust the angle and seal by (1) soldering the interface (2) distant soldering and sealing with silica gel for further adjustment

Assembly diagram (Fig. B)

- ① Check the quantity of the sections, and assemble them in sequence: A-A1, A1-A2, A2-A3 ...A[N-1] – A[N]

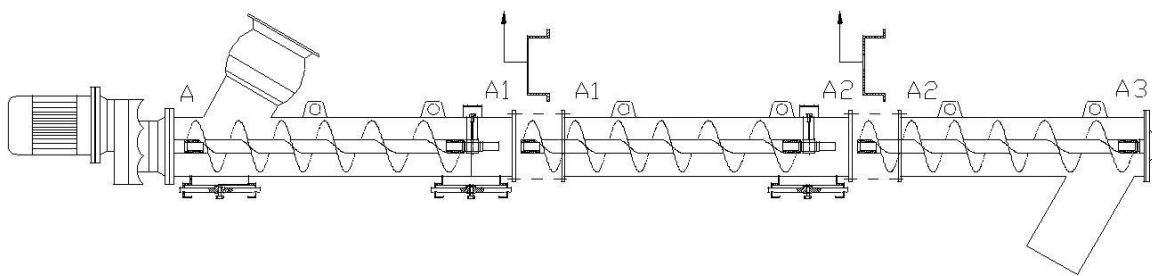

Caution 1: Connect the sections along the screw direction (see the figure at right).

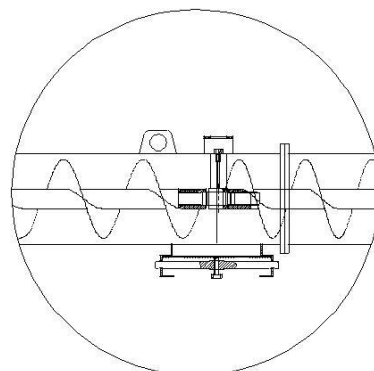

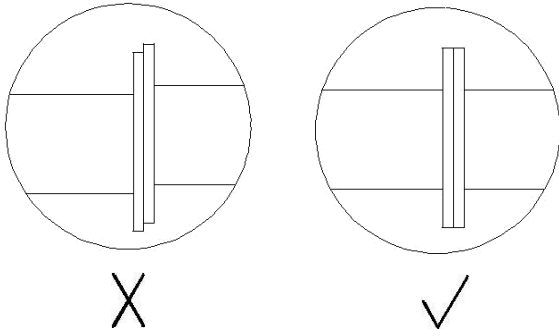

Caution 2: Connecting flanges shall be in parallel.

② Lock all the connecting parts, clean out packages and accessory settings before lifting the Screw conveyor with an appropriate lifter.

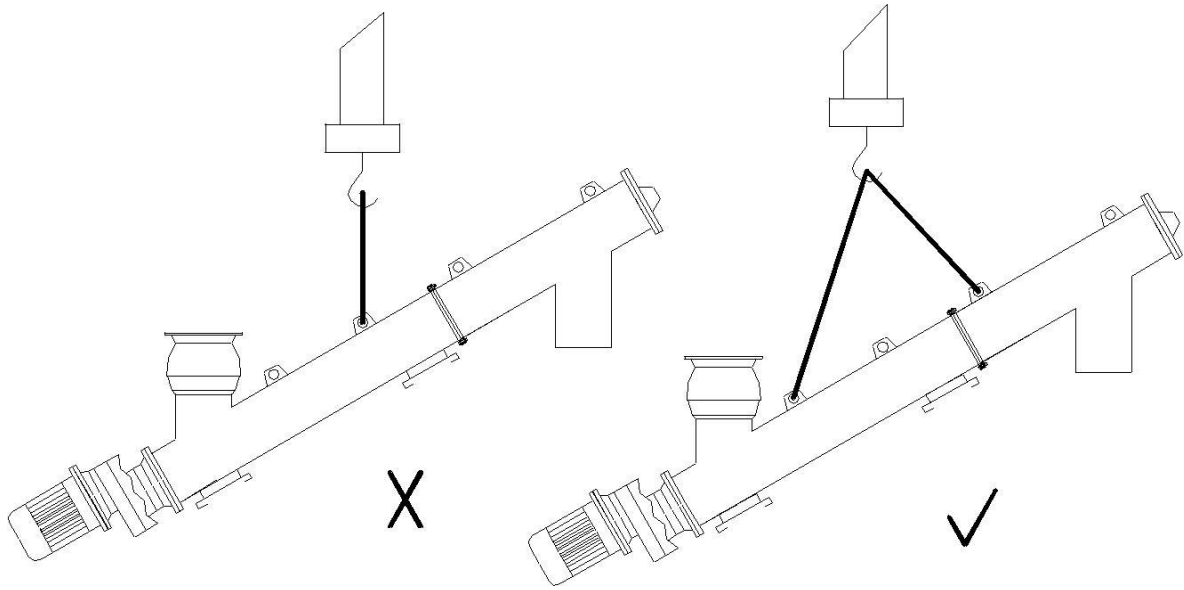

③ Support properly the Screw conveyor after the Inlet and Outlet are fixed.

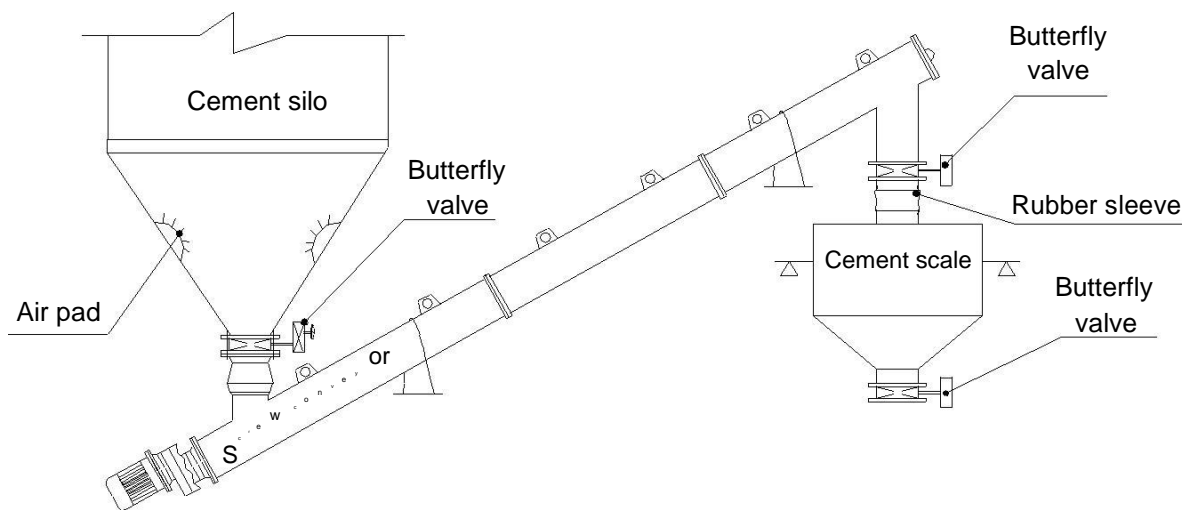

Note: We are specialist in supplying equipments for mixing stations. We also supply premium quality Air pads, Butterfly valves, Connecting seals and other components.

2. Circuit Connection

- ① Circuit shall be connected according to the instruction manual and technical data by a professional technician.
- ② Trial operating the machine after the circuitry is connected.

3. Safety precautions

(1) Before operating the Screw conveyor

- ① Remove all those maintenance accessories, warning plates, and other obstacles that may affect the normal operation of the machine
- ② Check if all the screws on the Tube are tightened
- ③ Check the mechanical function of the Inlet, Outlet, and the whole machine

(2) Repair

- ① Do not repair the Screw conveyor when it is working
- ② Place a signboard while repairing the machine: **“Warning: machine under repair, driving is forbidden”**. Meanwhile, shut off the power and keep it under watch.

(3) Use and maintenance

- ① Check the sealing and lubricating condition of the Gear reducer each week. Refill oil at standard level in time.
- ② Check if all the sections are connected tightly each month
- ③ Do not mingle hard impurities into the material
- ④ Replace grease oil after the Gear reducer has been operating for the first 100 hours, and replace grease oil again after each 1000 hours.
- ⑤ Repair and maintenance shall be done by technicians only.

Choose your Screw conveyor

Transmission quantity shall be calculated according to the density proportion of material to concrete
($\rho = 1.25 \text{ t/m}^3$)

Specification of Screw conveyors (Table 1)

Specification Motor Gear reducer	Φ 168	Φ 219	Φ 273	Φ 323	Φ 407
	17T/h	40T/h	80T/h	110T/h	170T/h
1000/1:5/38	>3~6M 3KW				
	>6~13M 5.5KW				
2000/1:7/38		>3~6M 5.5KW	>3~5M 7.5KW		
		>6~9M 7.5KW			
2000/1:7/42		>9~13M 11KW	>5~9M 11KW		
3000/1:7/42			>9~13M 15KW		
3000/1:10/42				>3~5M 11KW	
				>5~7M 15KW	
3000/1:10/48				>7~9M 18.5KW	>3~5M 18.5KW
				>9~11M 22KW	>5~7M 22KW
3000/1:10/55					>7~9M 30KW

Note: We can use Gear reducer and Motor with higher power if customer has special requirement.

Conveying capacity of our serial Screw conveyors

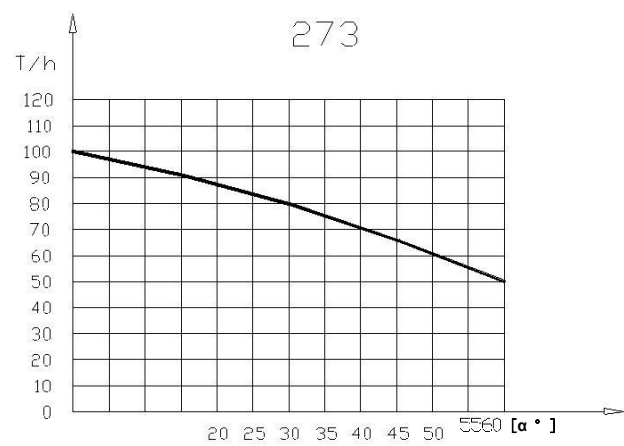
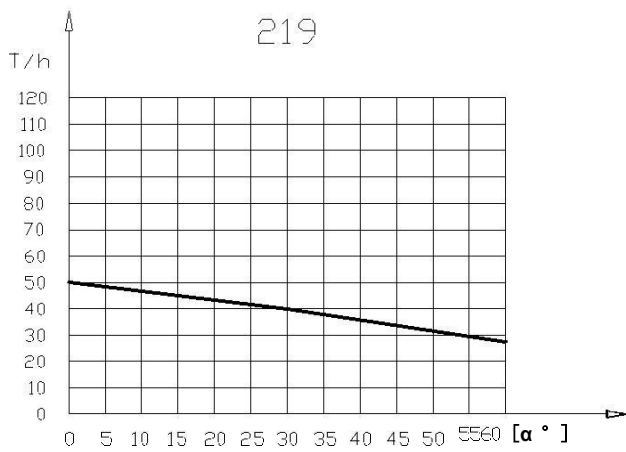

- Note:** 1. Conveying capacity is subject to the overall arrangement of the Mixing station;
 2. Capacity is subject to the material.

Defects and Trouble shooting

Defect	Position	Cause	Trouble shooting
Oil leakage	Gear reducer	Shaft sealing is worn	1. Replace the seal of the input shaft 2. Replace the seal of the output shaft
Cement leakage	Gear reducer	Shaft sealing pad is worn	Replace the sealing pad
	Inspection window	Unlocked	1. Tighten the screws of Inspection window 2. Use silica gel at the sealing
	Adjustable inlet	Joint	Solder or use silica gel at the joint of Adjustable inlet
Abnormal noise	Motor	Motor bearing is damaged	Replace the motor
	Gear reducer	Input shaft is damaged	Replace the bearing
		Dirty or lack of grease oil	Change grease oil and refill to 2/3 level of Inspection window
	Tube	Fly scratches the interior side of Tube	Adjust concentricity of the Fly
		Intermediate support broken	Replace the intermediate support
Transmission quantity shortage	Cement silo	No Air pad	Mount 6 Air pads
		Not enough material	Recharge material

***Note: Our products are under continuous improvement. We may not be able to inform you in advance if the data is changed. ***